



Providing the Ultimate Solutions in Precision
Displacement Sensors

[Order](#) • [Site
Map](#)

[Home](#) | [All Products](#) | [Support](#) | [Special Offers](#) | [Contact Us](#)

Home

Data Sheet - Series D60, D61 and D62 Miniature Position Transducers

High-Resolution, Digital-Output, Miniature Size

Shaded characteristics are verified during production and test. All others are for REFERENCE and information only.

Summary Features

- 43-inch (1092-mm) Maximum Travel (Series D62)
- Digital Signal Using Precision, High-Resolution Incremental Optical Encoder
- AccuTrak™ Threaded Drum for Enhanced Repeatability
- Bearing-Mounted Rotating Components
- Optional Flexible Mounting Bases
- Predicted Life: 10 Million Full-Stroke Cycles
- NEMA 4X / IP 66 Environmentally Protected
- DirectConnect™ Sensor-To-Drum Technology = Zero Backlash, No Torsion Springs or Clutches

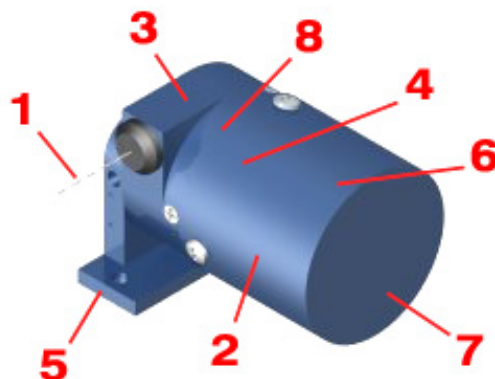

Sensor Specifications

SENSOR SPECIFICATIONS (incremental optical encoder)

Power Requirement	5 to 26 VDC
Current	35 mA max at 5 VDC
Logic Output	open collector with Schmitt trigger and 10 Kohm pull-up resistor (push-pull differential line driver)
Power Consumption	150 mW max, 16 mA sink current at 0.40 VDC
Travel: Electrical, Mechanical	360° continuous
Mechanical Life	100 million shaft revolutions min
Resolution	8192 quadrature pulses per revolution
Output	2-bit (quadrature) code, A leads B by 90° w/CW
Operating Temperature	-4° to 212° F (-20° to 100° C)
Shock / Vibration	50 g for 11 ms / 50 to 500 Hz at 20 g
Humidity	98% non-condensing

Other Specifications

Case/Drum Materials	precision-machined, anodized 2024 aluminum
Displacement Cable	0.027 inch (0.6858 mm) diameter, 7-by-7 stranded stainless steel, 90-lb (400-N) min breaking strength

Displacement Cable Hardware	1 each of 300196 loop sleeve , 300292 copper sleeve , 300688 ball-end plug , 300495 pull ring , 160026 brass swivel , and 301003 nickel swivel ; all items provided uncrimped
Nominal Mass	D60: 6 oz (170 g), D61: 8 oz (227 g), D62: 11 oz (312 g)
Environmental Sealing	NEMA 4X / IP 66

Part Numbers

Part Number	Nominal Range	Nominal Resolution#	Nominal Cable Tension	max Cable Accel.
(Order Code)	in (mm)	pulses/in (pulses/mm)	oz (N)	g
D60-090	11.25 (286)	3587 (141)	8 to 23 (2 to 6)	40
D60-170	21.25 (540)	1883 (74)	8 to 20 (2 to 6)	40
D61-244	30.50 (775)	1338 (53)	9 to 24 (3 to 7)	71
D62-345	43 (1092)	951 (37)	6 to 19 (2 to 5)	32

after quadrature decode by user

Electrical Connection

Electrical Connection Type	Pin/Wire Assignment	
10-conductor dark gray PVC cable with 24 AWG flying leads, 60-in (1524-mm) min length, 0.250 (6.35) nominal diameter, -20° to +80° C operating temperature range	Wire Color	
	red	common
	gray	+VDC
	brown	Z
	green	Z'
	blue	B
	orange	B'
	yellow	A
	white	A'
	purple	N/C
black	case	

Drawing

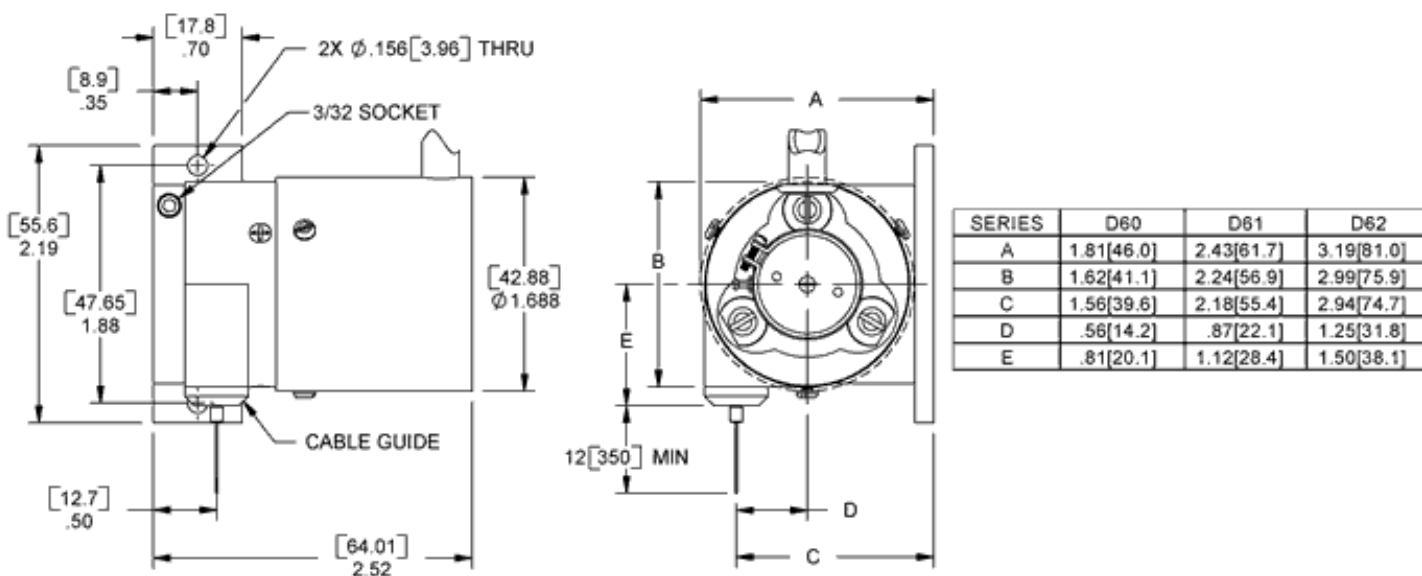

Related Products

Part Number	Description
160005	base: magnet (_6_)
160030-	base: universal (_6_)
160040-1	base: mounting disk (_6_)
160015-1	base: big foot (_6_)
160015-G1	base: h (_60)
300460	base: universal (miniature) (_60)
160001-01	installation kit

Options

Electrical Cable Termination	straight pins (two rows of 5 pins on 0.10" centers)
Input Signal	5 VDC \pm 5%
Output Signal	TTL or RS-422A line driver
Resolution	50% and 25% resolution
Operating Temperature	-40° to +185° F (-40° to +85° C)
Display Meter	LCD readout, two registers; scalable output
Interface Products	cables, adapters, interface circuits, power supplies

For crimping of hardware to displacement cable, consider the [160001-01 installation kit](#).

Need something not shown? Complete a [Custom Solution Request](#).

All dimensions are REFERENCE and are in inches [mm] Data Sheet Series D60, D61 and D62 Rev. -

[Firstmark Controls](#) • info@firstmarkcontrols.com

An ISO9001:2000/AS9100B-Compliant Company
 1176 Telecom Drive • Creedmoor, NC 27522 USA
 Phone: 1-919-956-4203 • Fax: 919-682-3786 • Toll Free: 1-866-912-6232

Business hours: Mon-Fri, 8:00am to 5:00pm (Eastern time)

All specifications subject to change without notice.
 © 1996-2008 Firstmark Controls All rights reserved.

[top](#)

[News](#) • [Representatives](#) • [Request Literature](#) • [CAD Models](#) • [Calculators](#)

[top](#)